

Stand 26.05.2011

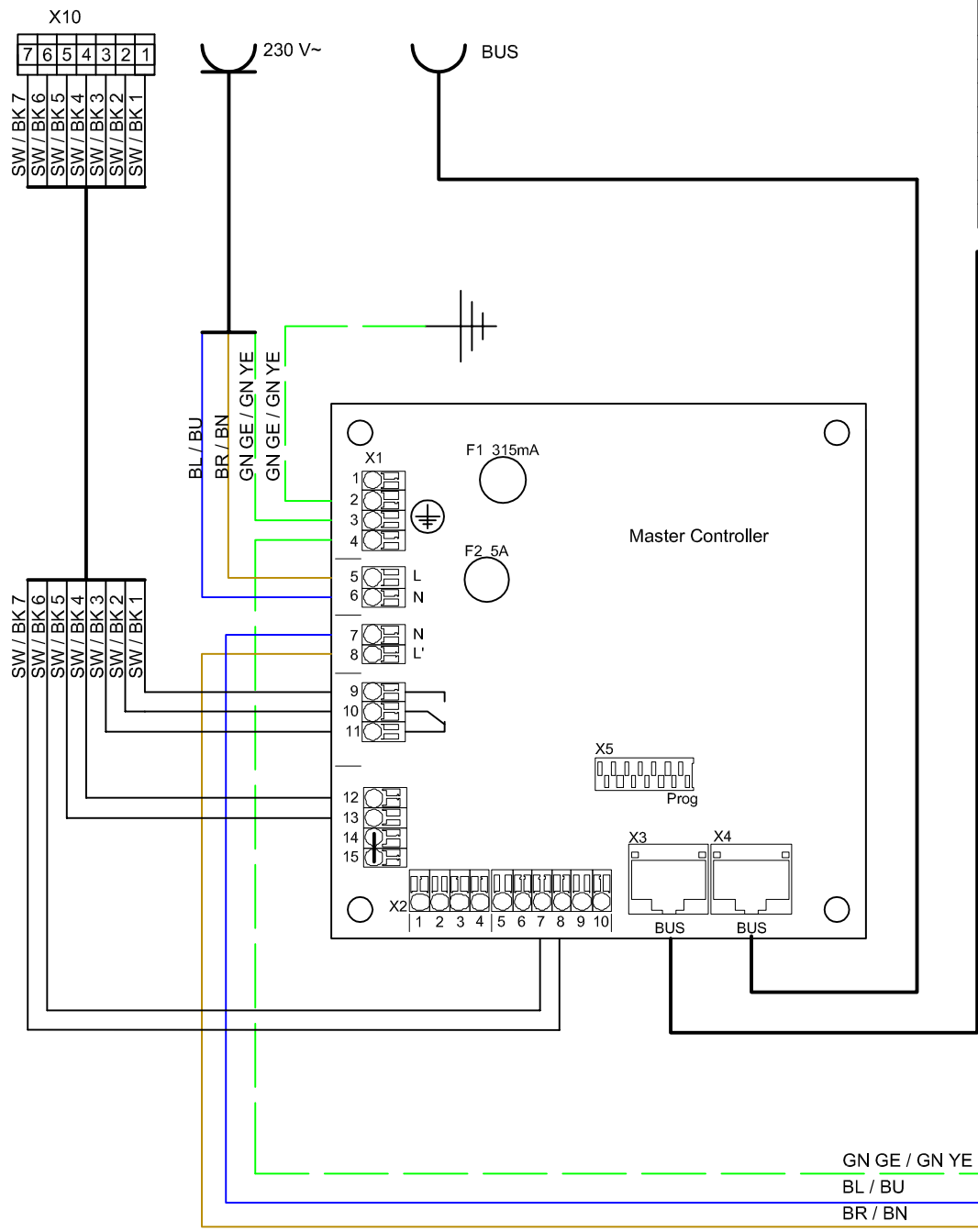

X10 Klemme für externe Beschaltung / terminal for external connection

Nr.	Funktion
1	Statusrelais Schließer / status relay make contact
2	Statusrelais Wechsler/ status relay changeover contact
3	Statusrelais Öffner / status relay break contact
4	Stoßlüftung / push ventilation
5	Stoßlüftung / push ventilation GND
6	analoger Eingang / analog input 0-10V; 4-20mA
7	analoger Eingang / analog input GND

Version / version: Links/Rechts left/right

	Links / left	Rechts / right
S2-1	OFF	ON
Außenluft / Intake air	T1	T3
Zuluft / Supply air	T2	T4
Abluft / Extract air	T3	T1
Fortluft / Exhaust air	T4	T2
Ventilator 1 / fan 1	Zuluft / Supply air	Fortluft / Exhaust air
Ventilator 2 / fan 2	Fortluft / Exhaust air	Zuluft / Supply air

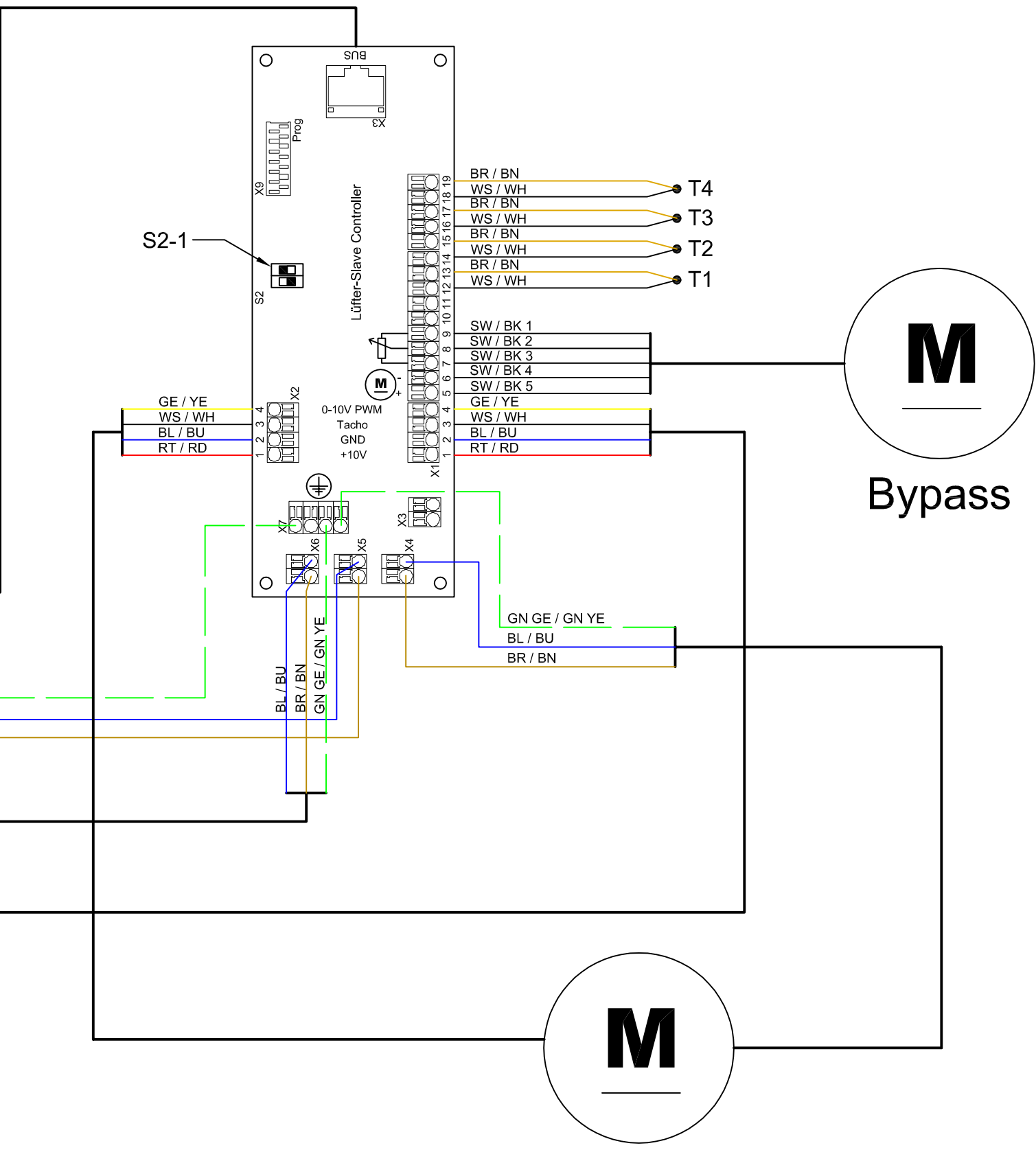

Ventilator / fan 1

Ventilator / fan 2